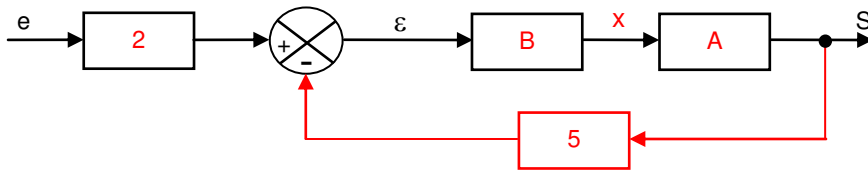

Exercice 1:

Passage d'un système d'équation à un schéma fonctionnel :

$$\varepsilon = 2e - 5S, S = A.x \text{ et } x = B \varepsilon$$

**Exercice 2:**

Passage d'un schéma fonctionnel à un système d'équation:

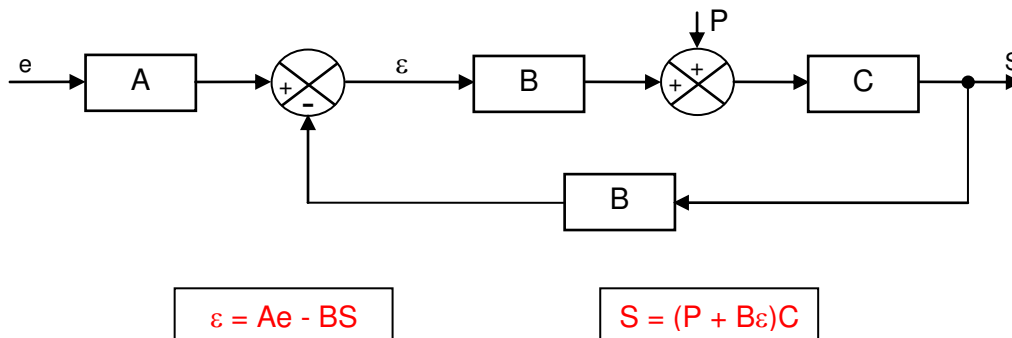
**Exercice 3:**

a)

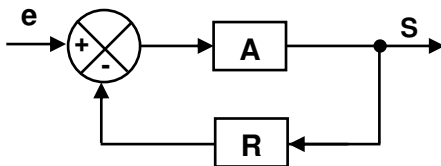

D'après la formule de BLACK :

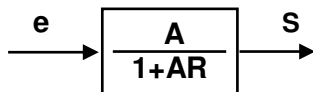

$$S = \frac{A}{1+AR} e$$

b)

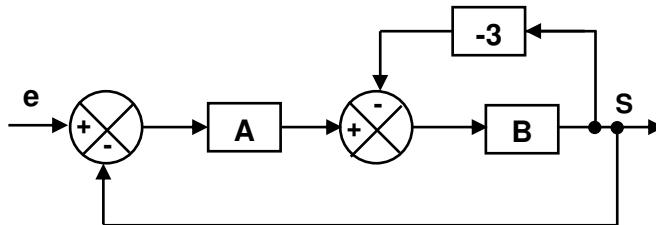
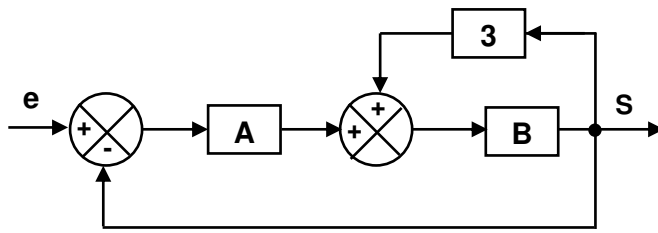

D'après la formule de BLACK :

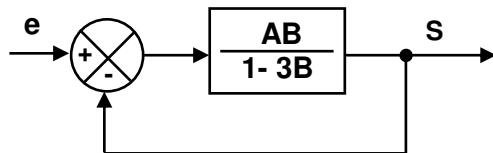
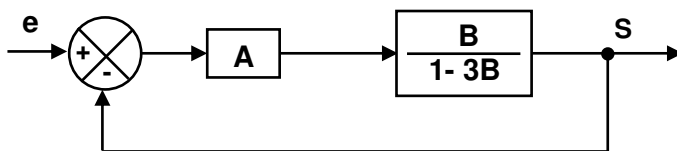

D'après la formule de BLACK :

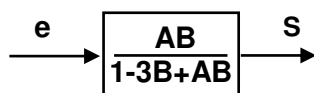
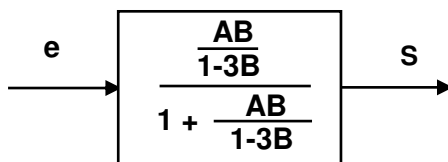

$$S = \frac{AB}{1-3B+AB} e$$

c)

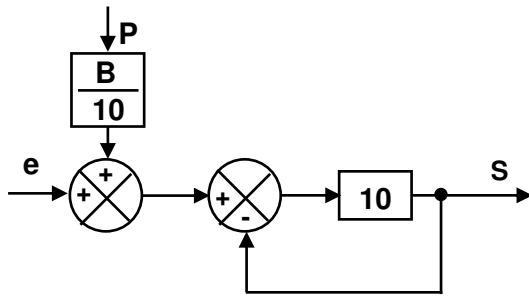
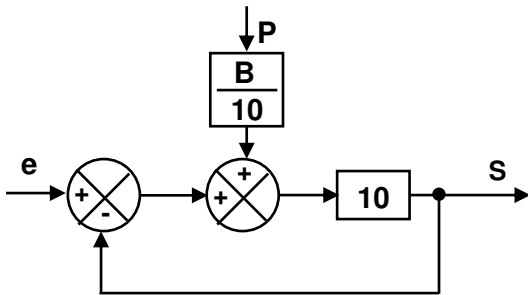
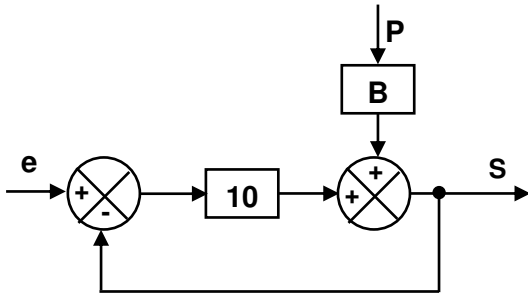

D'après la formule de BLACK :

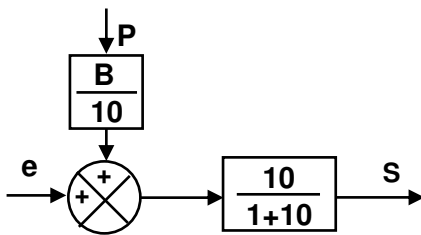

$$s = \frac{10}{11} e - \frac{B}{11} P$$

d)

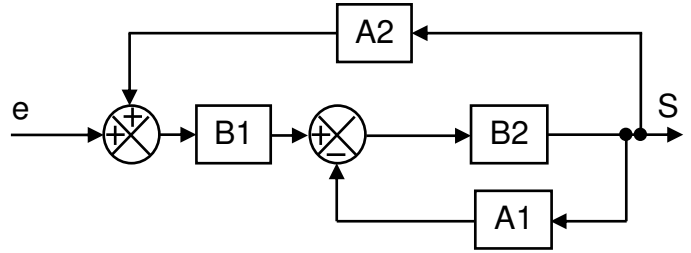

D'après la formule de BLACK :

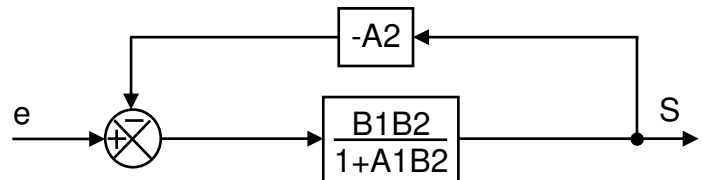
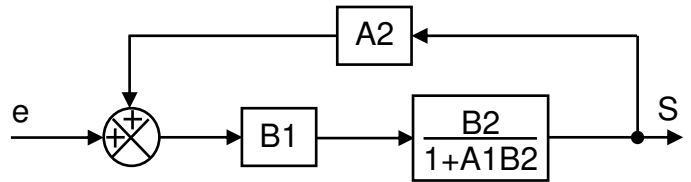

D'après la formule de BLACK :

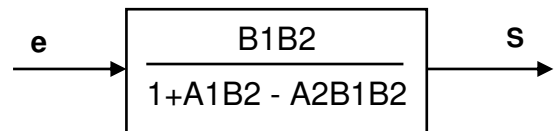
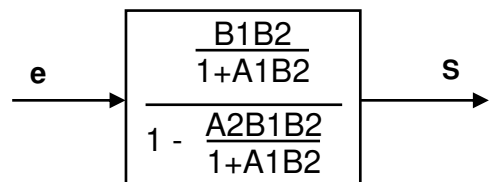

$$S = \frac{B1B2}{1+A1B2 - A2B1B2} e$$

Exercice 4:

1- Etude de la fonction F₁ :

a. $V_c = \frac{15}{300} nc$ $V_c = 0,05.nc$

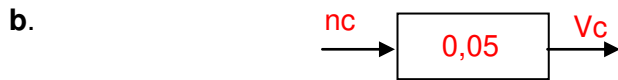

2- Etude de la fonction F₂ :

a. **Maille MABDCM :**

$V_c - Ri_1 + V_d + Ri_2 - Vr = 0$ ($V_d = 0$, régime linéaire)

$R(i_1 - i_2) = V_c - Vr$

Maille MEDBM :

$\epsilon + Ri_2 - Vr = 0$ ($V_d = 0$, régime linéaire)

$R(i_1 - i_2) = \epsilon$ $\epsilon = V_c - Vr$

b. c'est un comparateur

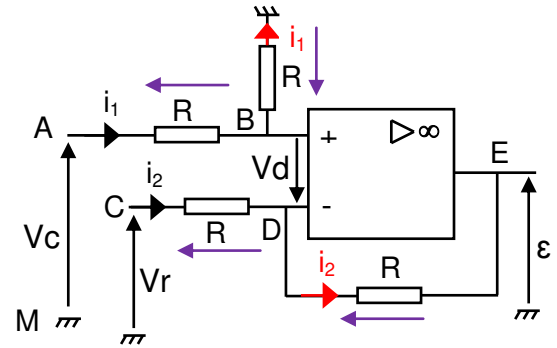
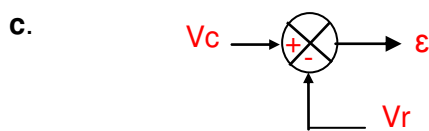

3- Etude de la fonction F₃ :

a.

Maille MABM :

$\epsilon - Ri_3 + V_d = 0 ; Ri_3 = \epsilon$ ($V_d = 0$, régime linéaire)

Maille MCBM :

$U_1 + 3Ri_3 + V_d = 0 ; U_1 = -3Ri_3$ ($V_d = 0$, régime linéaire)

b. $U_1 = -3\epsilon$

Maille MABM :

$U_1 - Ri_4 + V_d = 0 ; U_1 = Ri_4$ ($V_d = 0$, régime linéaire)

Maille MCBM :

$U_H + 2Ri_4 + V_d = 0 ; U_H = -2Ri_4$ ($V_d = 0$, régime linéaire)

$U_H = -2U_1$

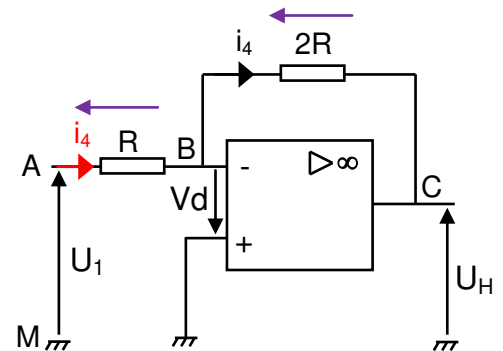
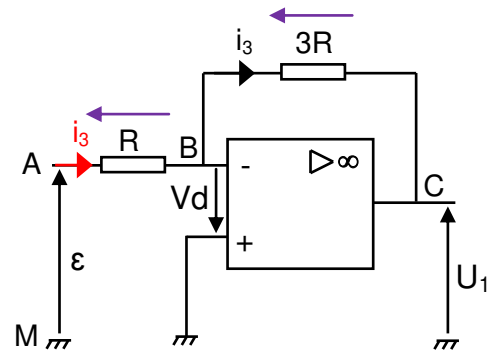
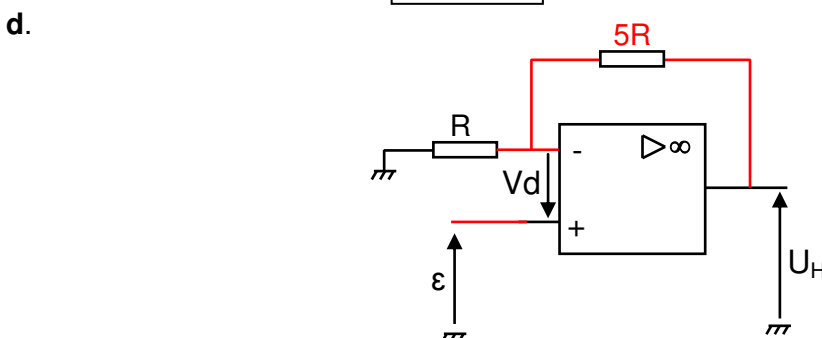
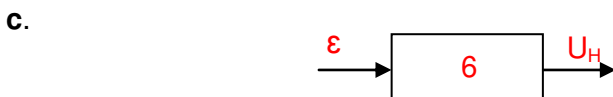

4- Etude de la fonction F_4 :

a.

Maille MABM :

$V_1 - Ri_5 + V_d = 0 ; V_1 = Ri_5$ ($V_d = 0$, régime linéaire)

Maille MCBM :

$V_r + Ri_5 + V_d = 0 ; V_r = -Ri_5$ ($V_d = 0$, régime linéaire)

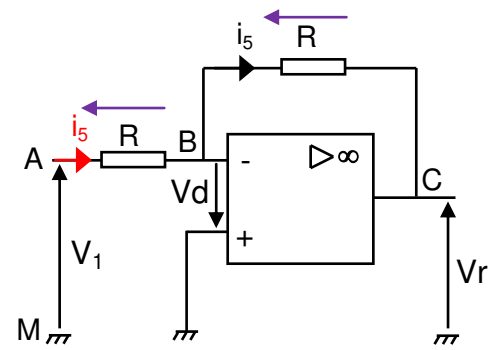

$V_r = -V_1$

b.

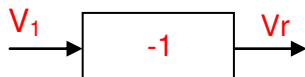

5- Schéma fonctionnel du système :

a.

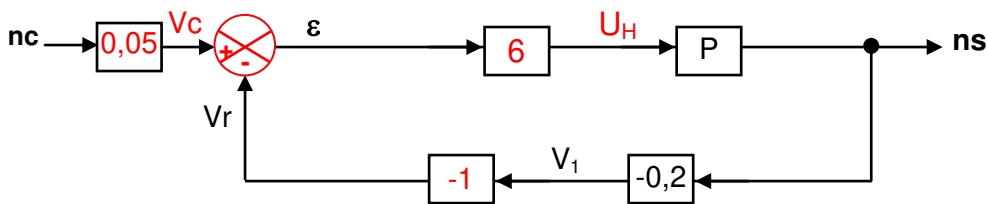

b.

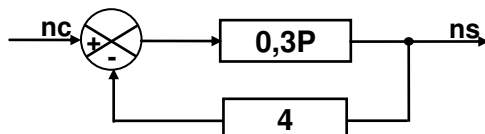
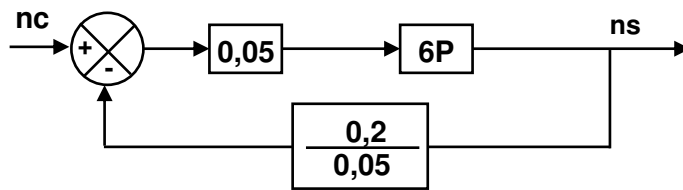
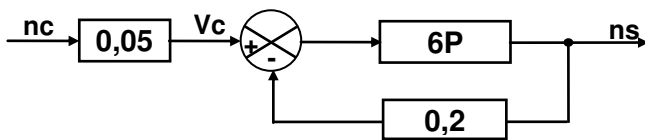

c. Utiliser la formule de black pour exprimer la transmittance $T = \frac{ns}{nc}$

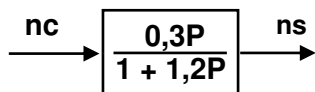

$T = \frac{0,3P}{1 + 1,2P}$

Exercice 5 :**ETUDE DES ETAGES DU SCHEMA STRUCTUREL DE REGULATION DE POSITION :****Etude de la fonction F1 :**

Exprimer V_c en fonction de θ_c sachant que : $V_{réf} = 12V$; $\theta_c \text{ max} = 300^\circ$ et $\theta_c \text{ min} = 0^\circ$.

$$V_c = \frac{12}{300} \theta_c$$

$$V_c = 0,04 \theta_c$$

Etude de la fonction F5

Exprimer V_s en fonction de θ_s sachant que : $\theta_s \text{ max} = 320^\circ$ et $\theta_s \text{ min} = 0^\circ$.

$$V_s = \frac{12}{320} \theta_s$$

$$V_s = 0,0375 \theta_s$$

Etude de la fonction F2 :

En appliquant les lois des mailles et des nœuds exprimer ε en fonction de V_c et V_2 .

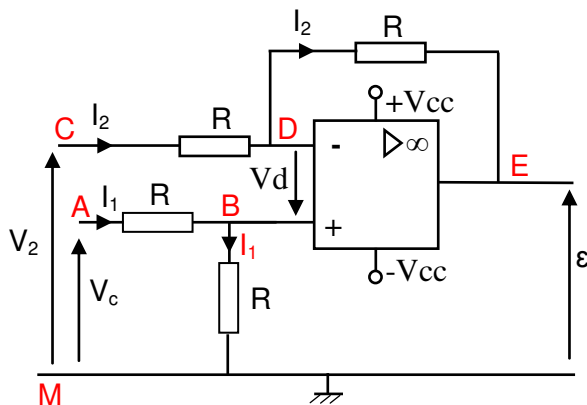
**Maille MABM**

$$V_c - RI_1 - RI_1 = 0$$

$$V_c = 2RI_1$$

$$I_1 = \frac{V_c}{2R}$$

Maille MCDEM

$$V_2 - RI_2 - RI_2 - \varepsilon = 0$$

$$V_2 - \varepsilon = 2RI_2$$

$$I_2 = \frac{V_2 - \varepsilon}{2R}$$

Maille MEDBM

$$\varepsilon + RI_2 + V_d - RI_1 = 0 \quad (V_d = 0 : \text{régime linéaire})$$

$$\varepsilon + R \frac{(V_2 - \varepsilon)}{2R} - R \frac{V_c}{2R} = 0$$

$$\varepsilon + \frac{V_2}{2} - \frac{V_c}{2} - \frac{\varepsilon}{2} = 0$$

$$\varepsilon = V_c - V_2$$

Etude de la fonction F3 :

En appliquant les lois des mailles et des nœuds exprimer V_1 en fonction de ε et K ; sachant que ($0 < K < 20$).

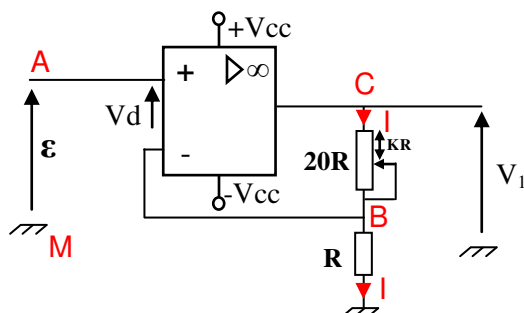
**Maille MABM**

$$\varepsilon - V_d - RI = 0$$

$$\varepsilon = RI$$

$$I = \frac{\varepsilon}{R}$$

Maille MCBM

$$V_1 - KRI - RI = 0$$

$$V_1 - RI(K + 1) = 0$$

$$V_1 = (K + 1)RI$$

$$V_1 = (K + 1)R \frac{\varepsilon}{R}$$

$$V_1 = (K + 1)\varepsilon$$

Etude de la fonction F6 :

En appliquant les lois des mailles et des nœuds exprimer V_2 en fonction de V_s .

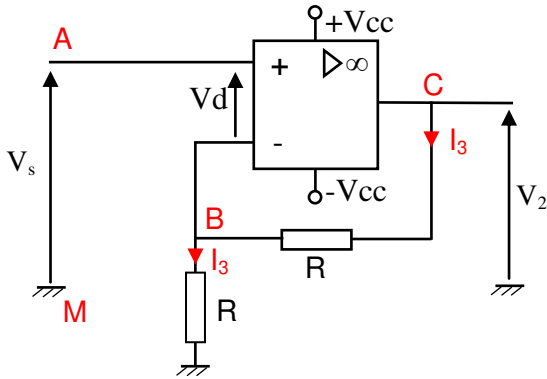

Maille MABM

$$V_s - V_d - R I_3 = 0$$

$$V_s = R I_3$$

$$I_3 = \frac{V_s}{R}$$

Maille MCBM

$$V_2 - R I_3 - R I_3 = 0$$

$$V_2 = 2 R I_3$$

$$V_2 = 2 R \frac{V_s}{R}$$

$$V_2 = 2 V_s$$

Etude de la fonction F4 :

Compléter le tableau par les mots suivants : saturé, passante, bloqué(e), arrêt, sens1, sens2.

V1	D1	D2	T1	T2	rotation du moteur
>0	passante	bloquée	saturé	bloqué	sens1
<0	bloquée	passante	bloqué	saturé	sens2
=0	bloquée	bloquée	bloqué	bloqué	arrêt

Schéma fonctionnel global :

Schéma fonctionnel global du système de régulation de position :

